

P/N: AMT-DP20180

Technical Specification

	Frequency Range(GHz)	2.0-18.0GHz
	Gain(dBi)	10 Typ.
	Polarization	Dual Polarized
	Port to Port Isolation(dB)	20 Min.
	Cross Polarization Isolation(dB)	20 Min.
	Impedance(Ohms)	50
	Connector	SMA-Female
	VSWR	2.5 Max.
	Material	Al
	Size(mm)	110 x 110 x 105
	Weight(g)	450 approx.

Outline (mm)

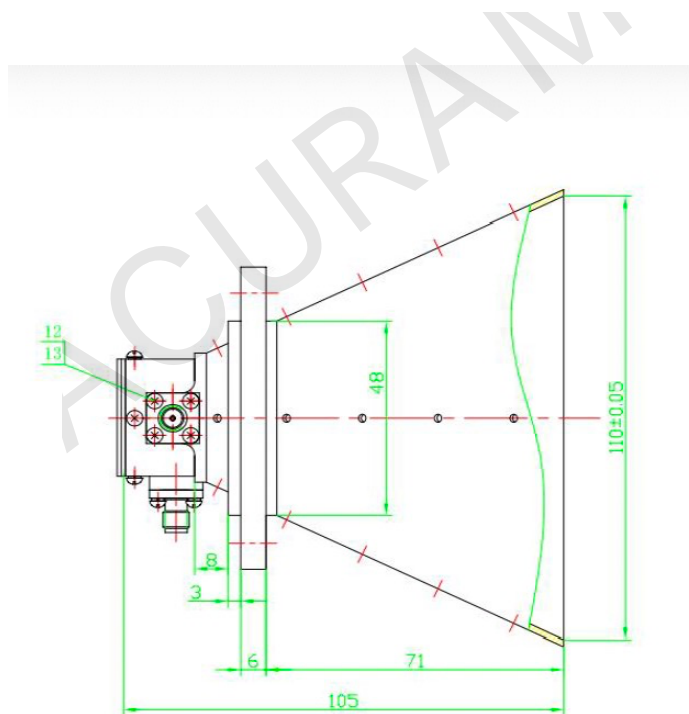

Test Result**Gain**

Frequency	Gain
2.0	5.57
3.0	6.24
4.0	9.48
5.0	9.71
6.0	12.16
7.0	12.41
8.0	13.01
9.0	11.69
10.0	11.86
11.0	11.36
12.0	11.60
13.0	10.54
14.0	10.07
15.0	11.60
16.0	15.26
17.0	16.46
18.0	15.57

VSWR

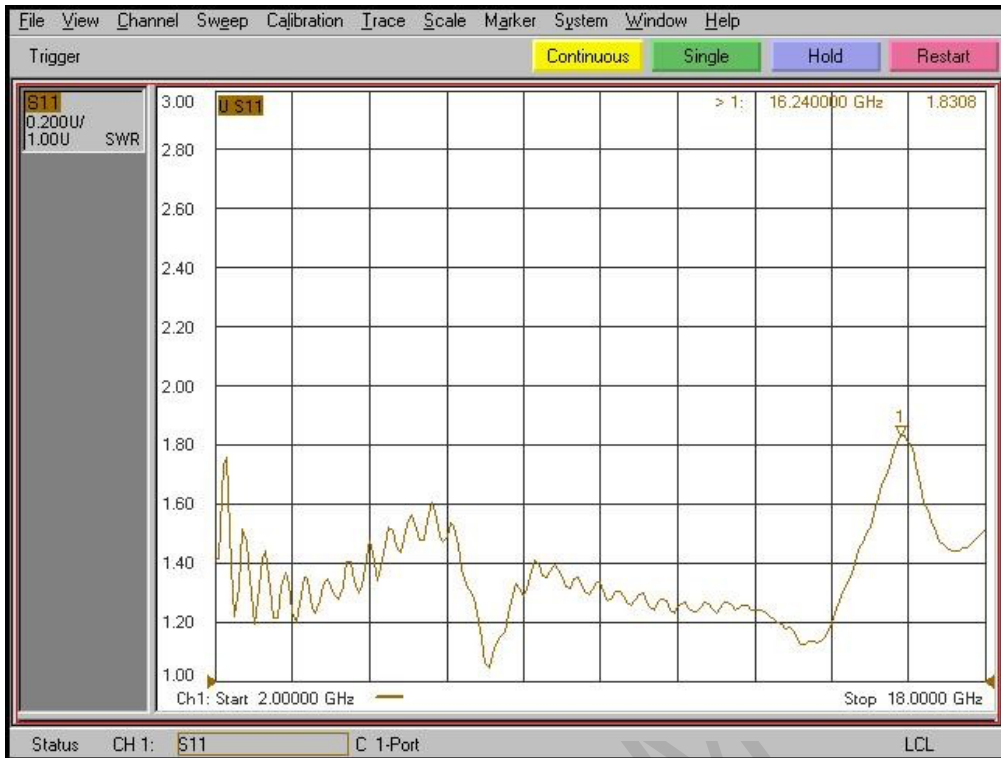

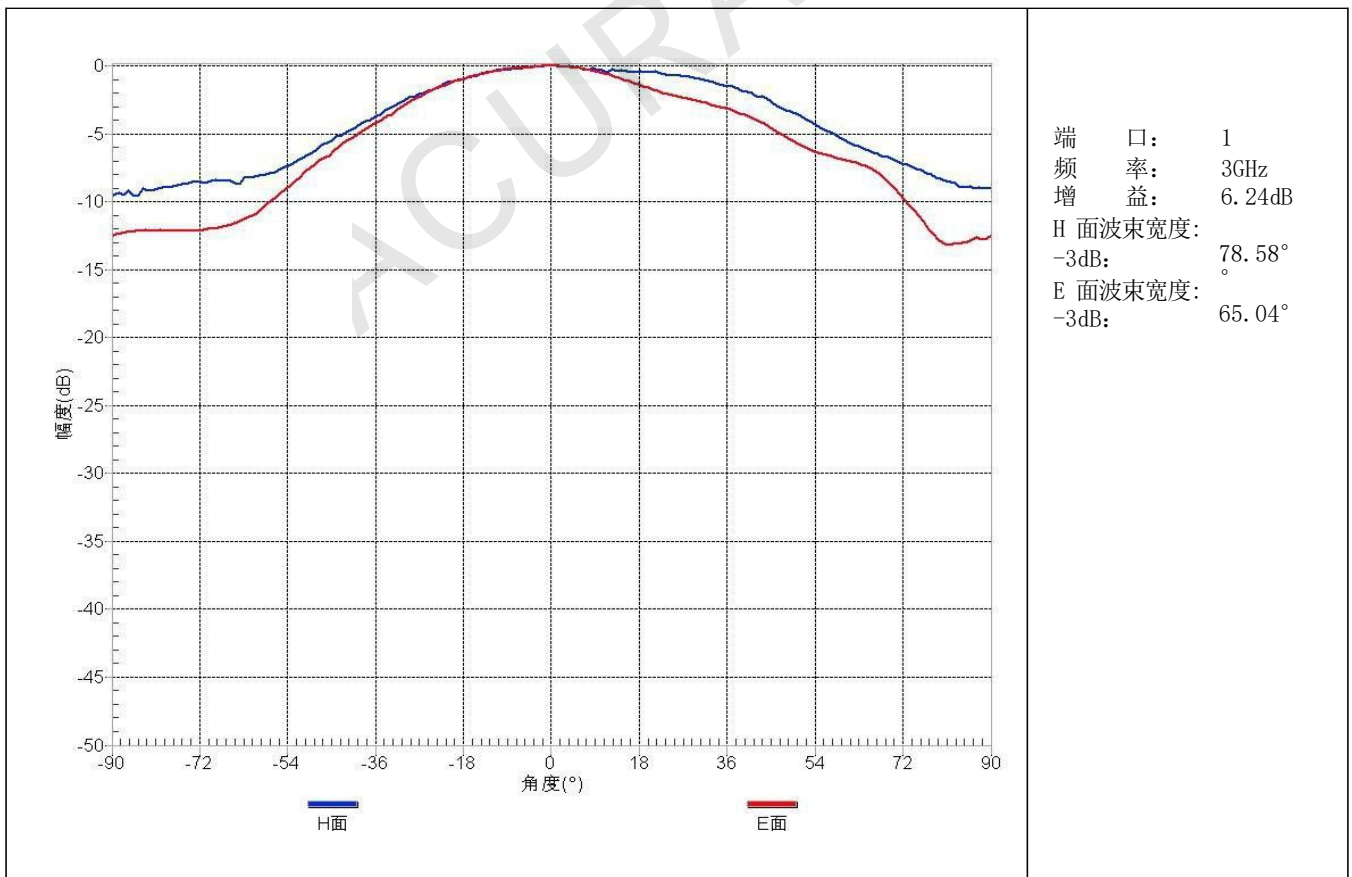
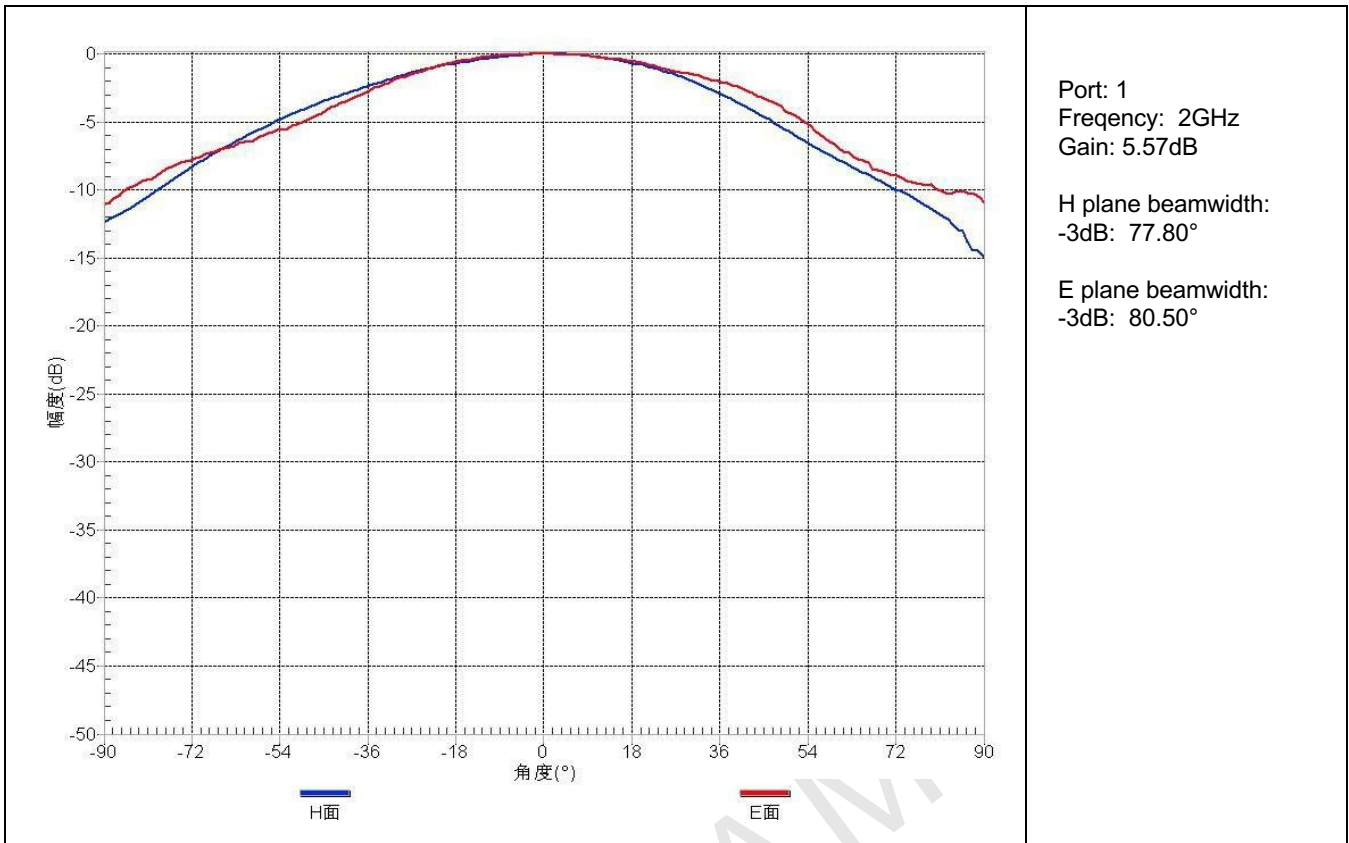

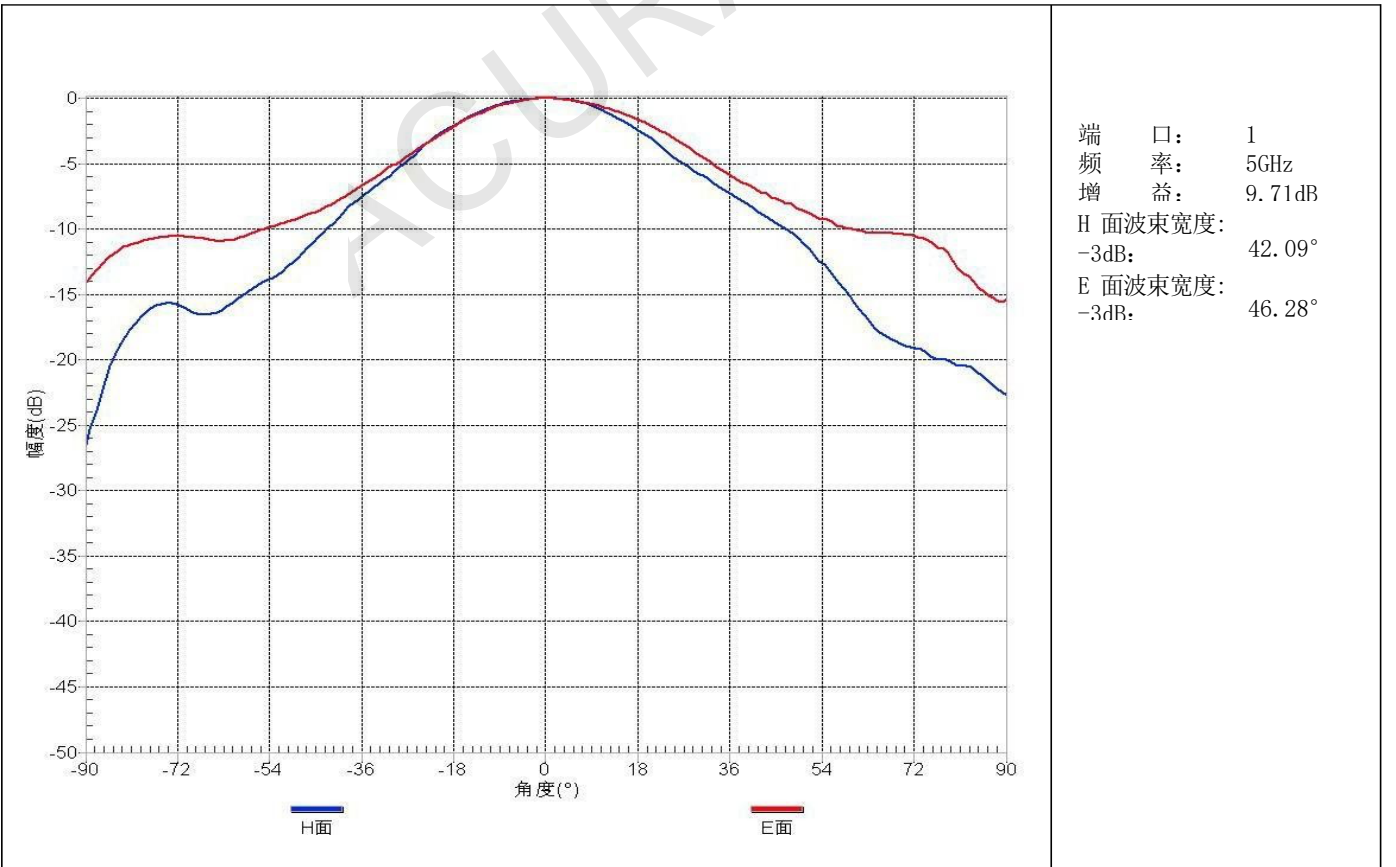
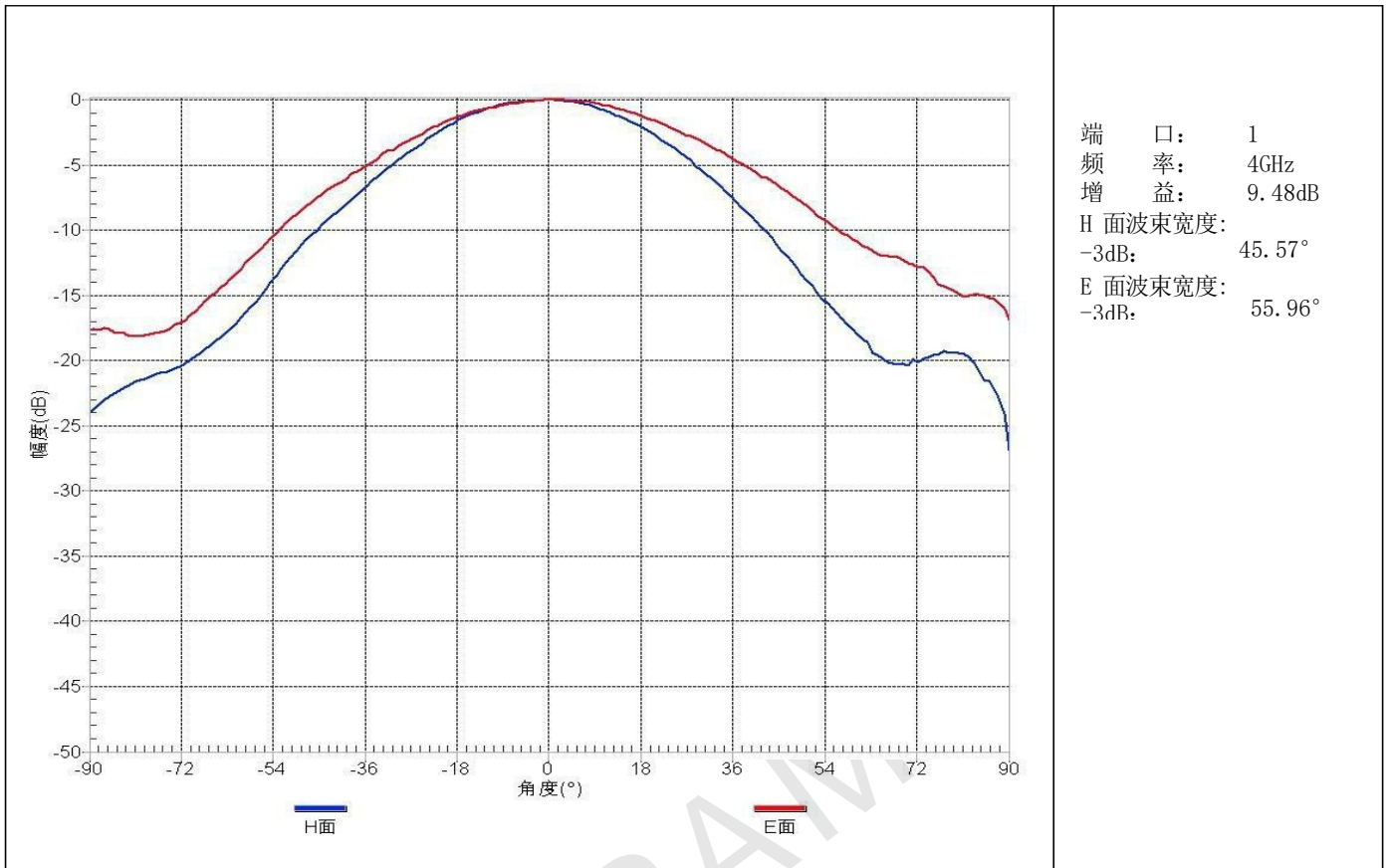

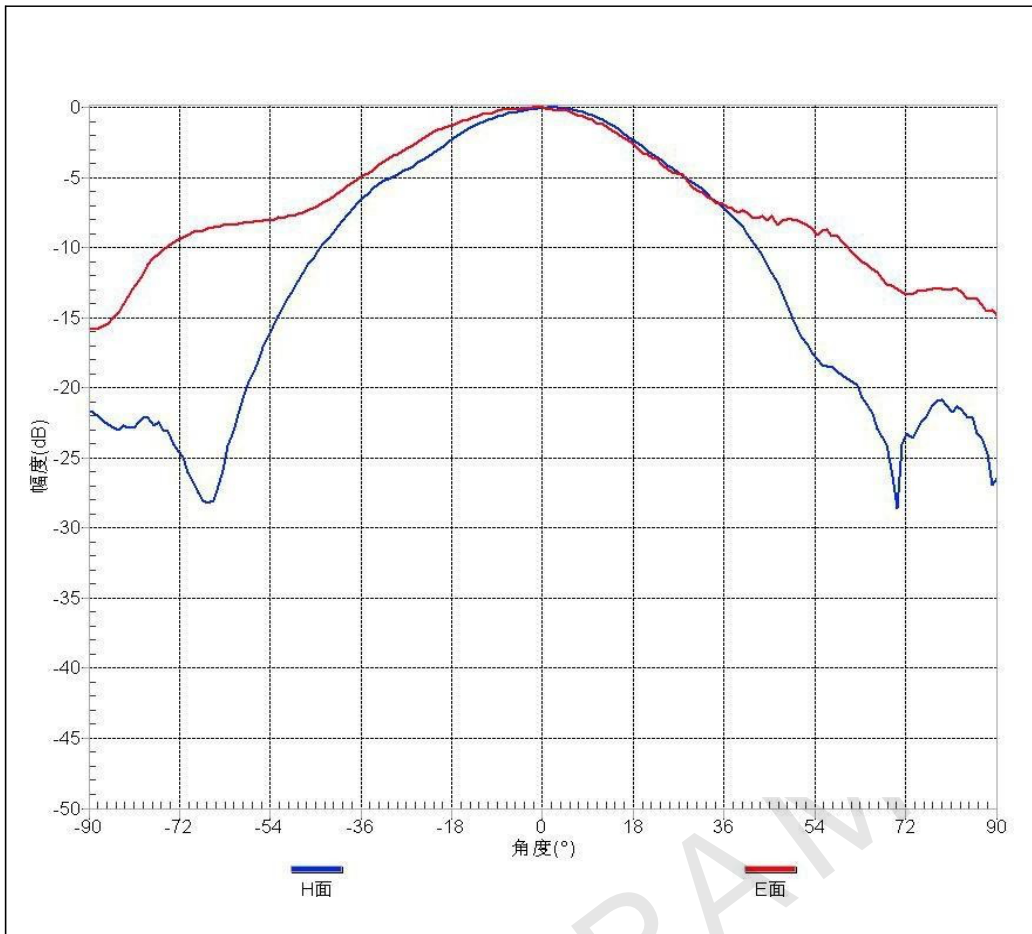

端 口: 1
 频 率: 6GHz
 增 益: 12.16dB
 H 面波束宽度:
 -3dB: 41.22°
 E 面波束宽度:
 -3dB: 46.32°



端 口: 1
 频 率: 7GHz
 增 益: 12.41dB
 H 面波束宽度:
 -3dB: 39.13°
 E 面波束宽度:
 -3dB: 39.26°

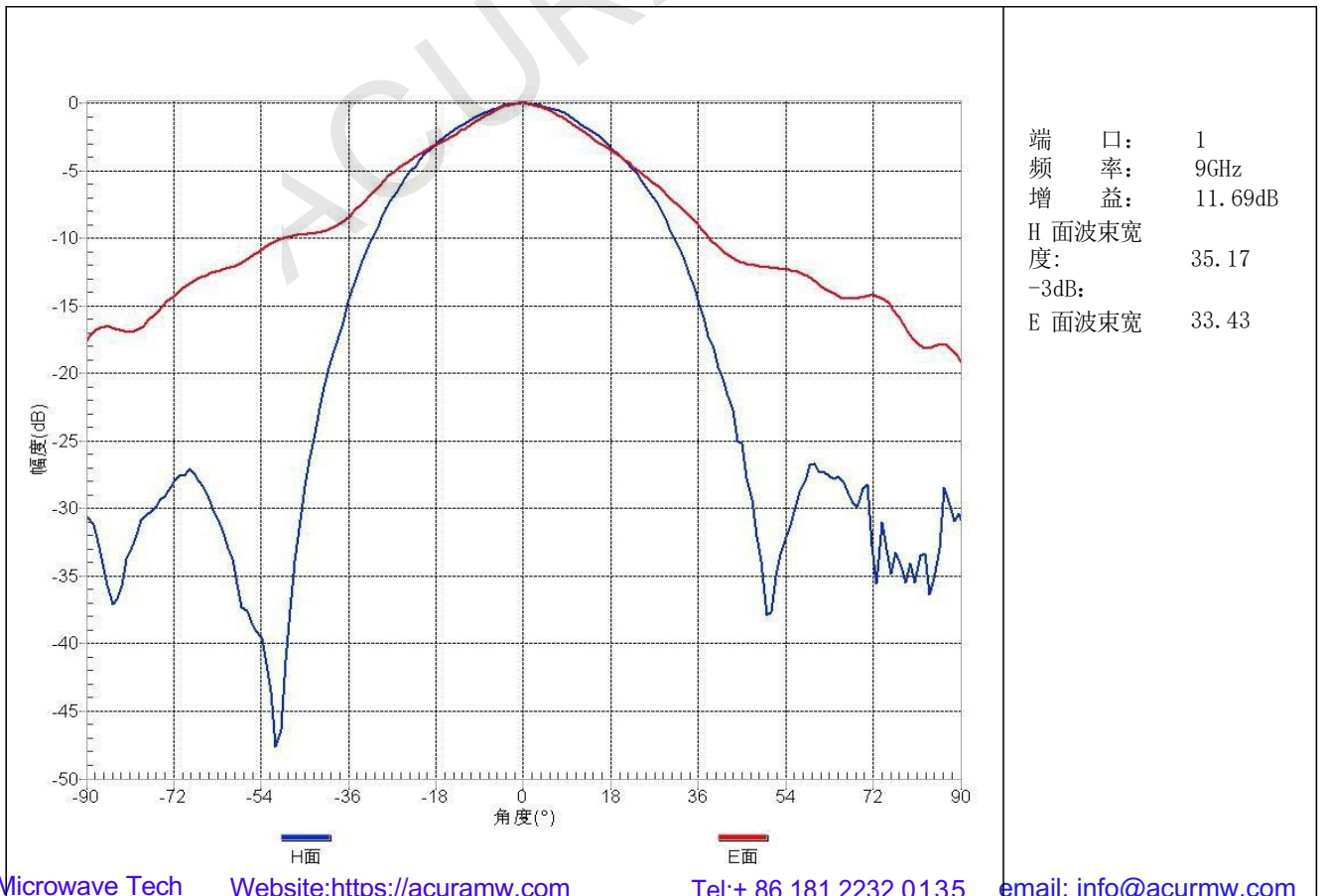
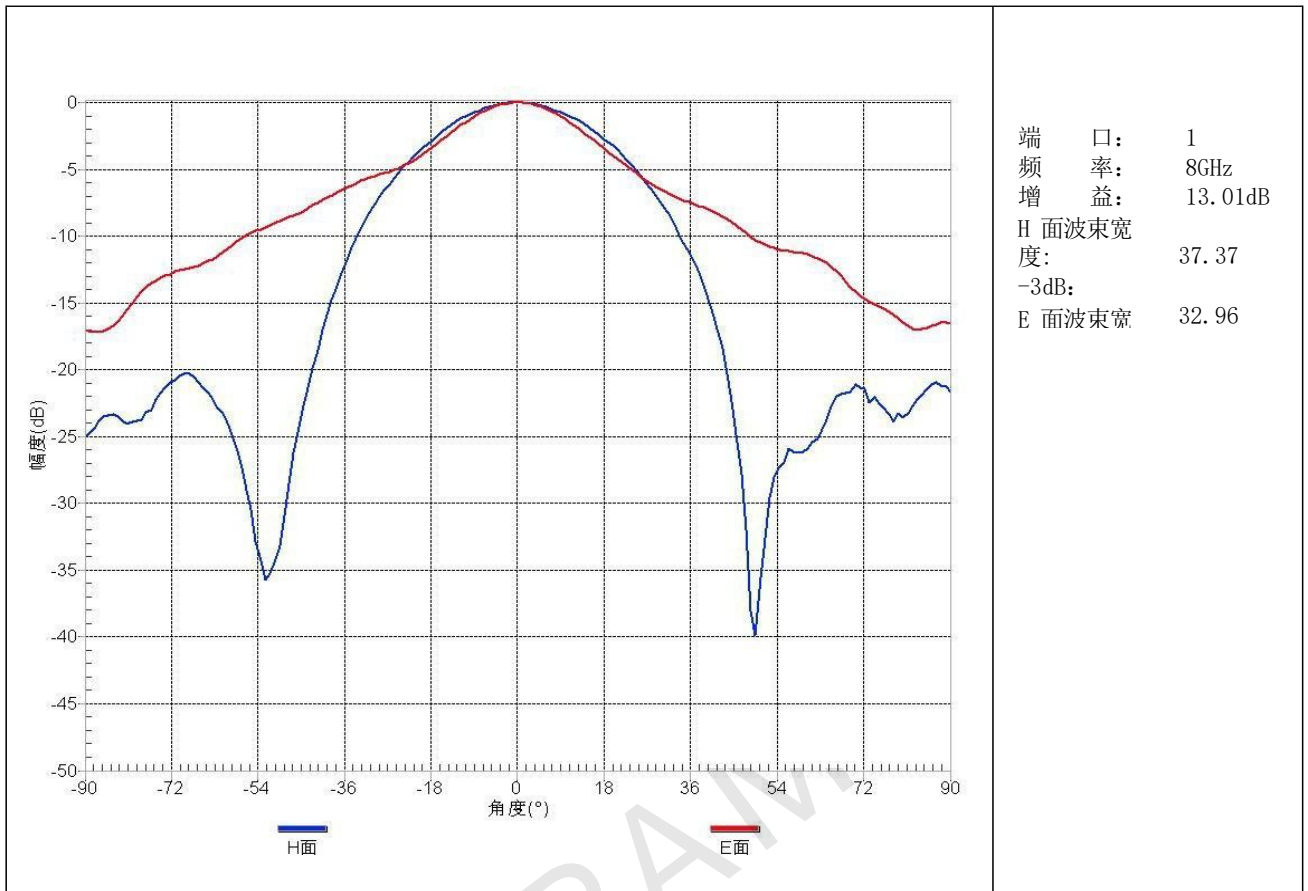

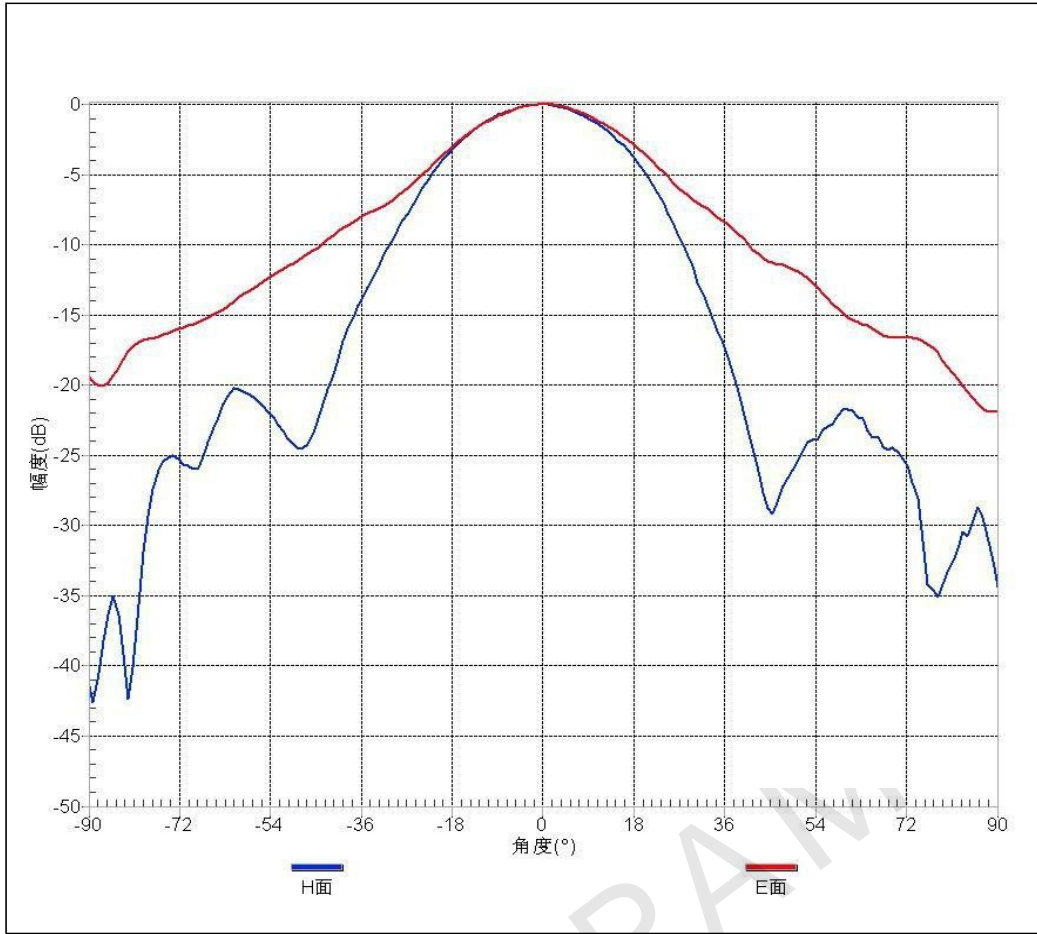

端 口: 1
 频 率: 10GHz
 增 益: 11.86dB
 H 面波束宽度:
 -3dB: 33.56°
 E 面波束宽度:
 -3dB: 36.42°



端 口: 1
 频 率: 11GHz
 增 益: 11.36dB
 H 面波束宽度:
 -3dB: 32.35°
 E 面波束宽度:
 -3dB: 41.63°

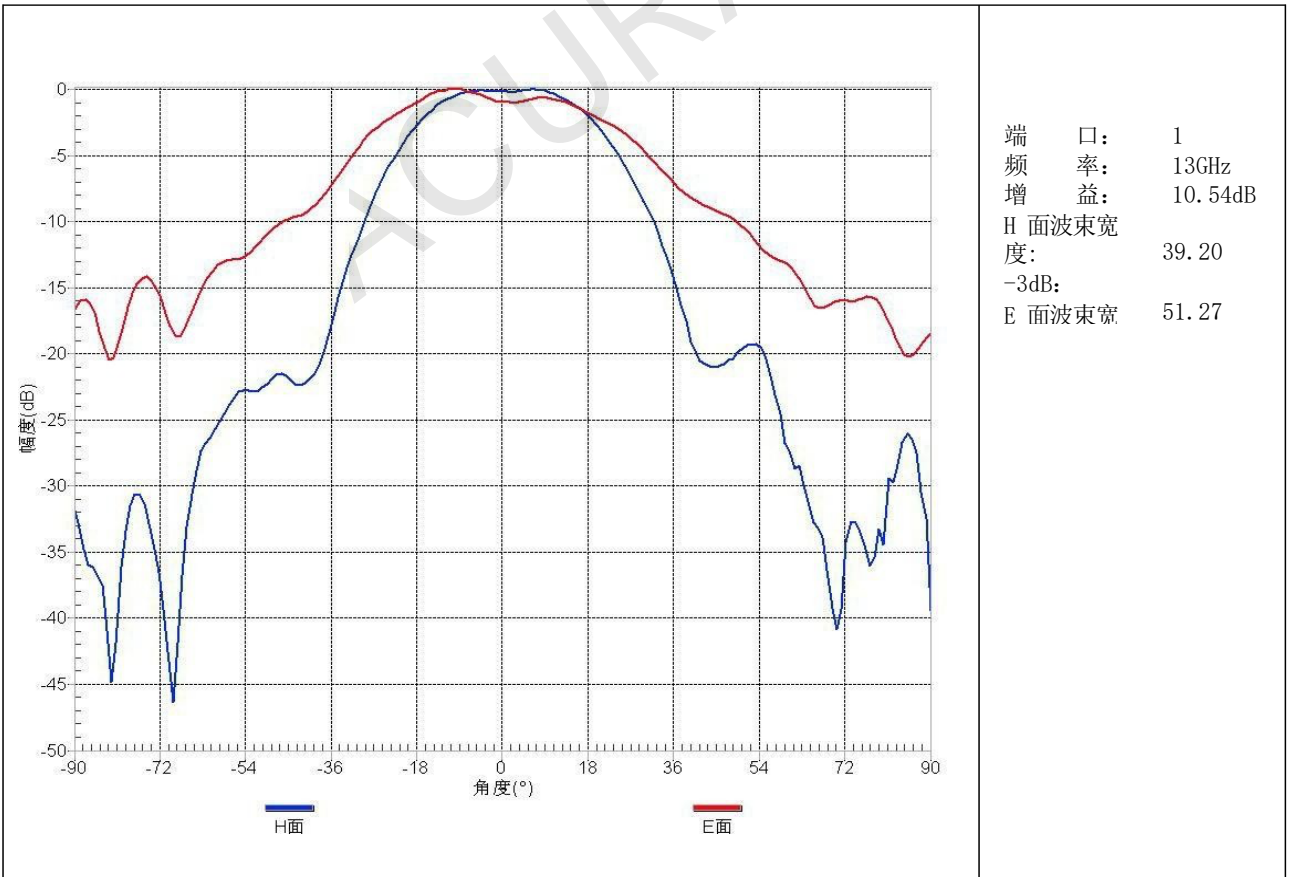
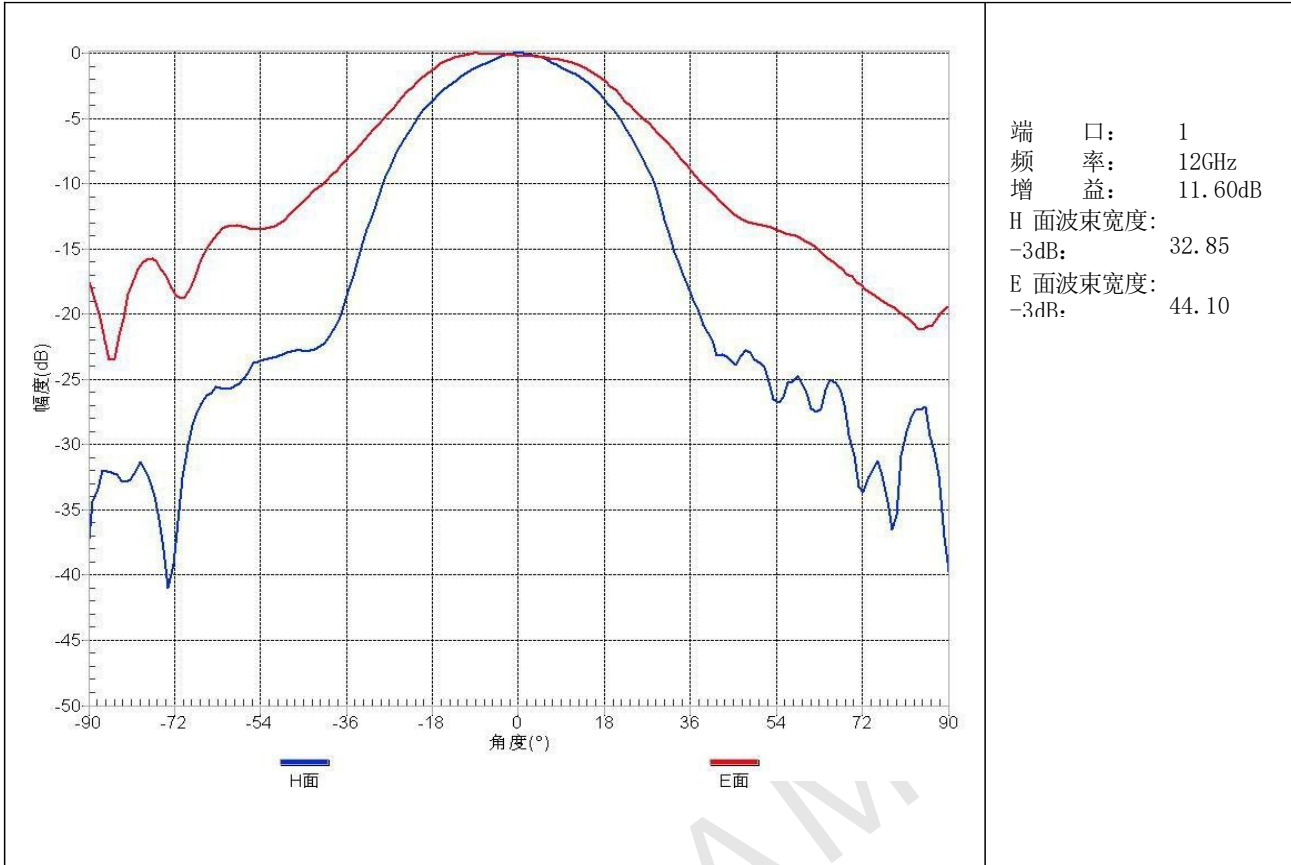

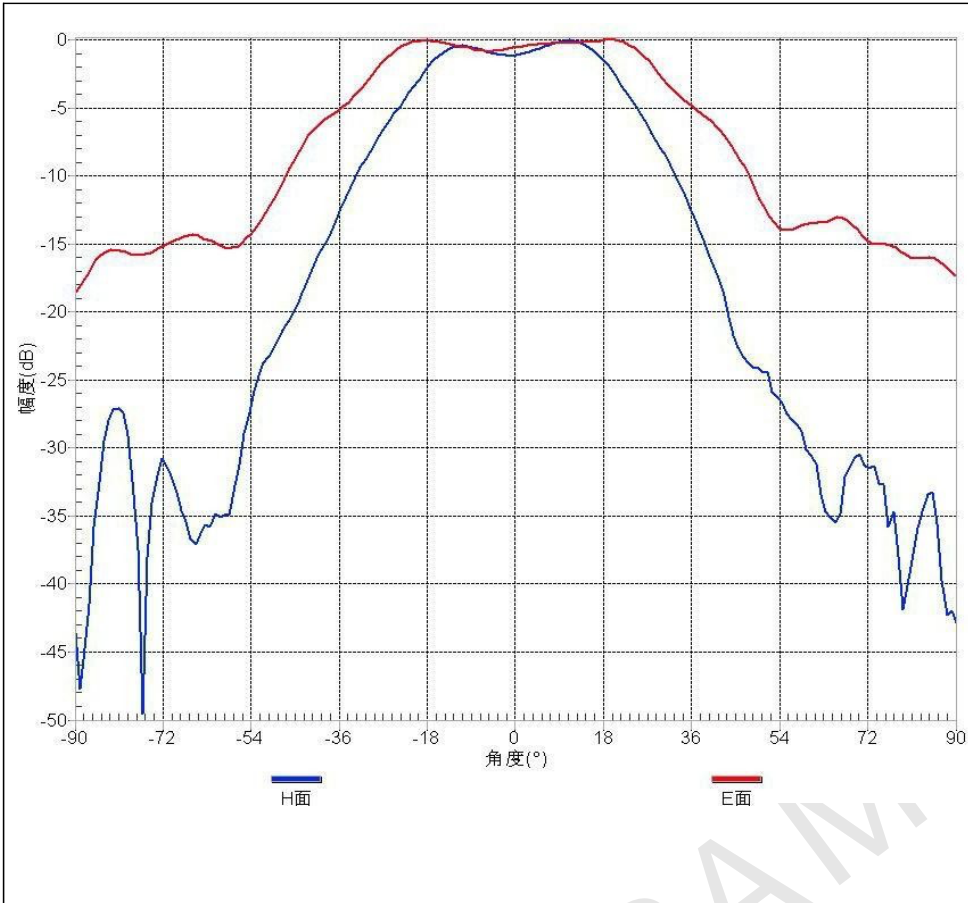

端口: 1
 频率: 14GHz
 增益: 10.07dB
 H 面波束宽度:
 -3dB: 41.04
 E 面波束宽度:
 -3dB: 60.78

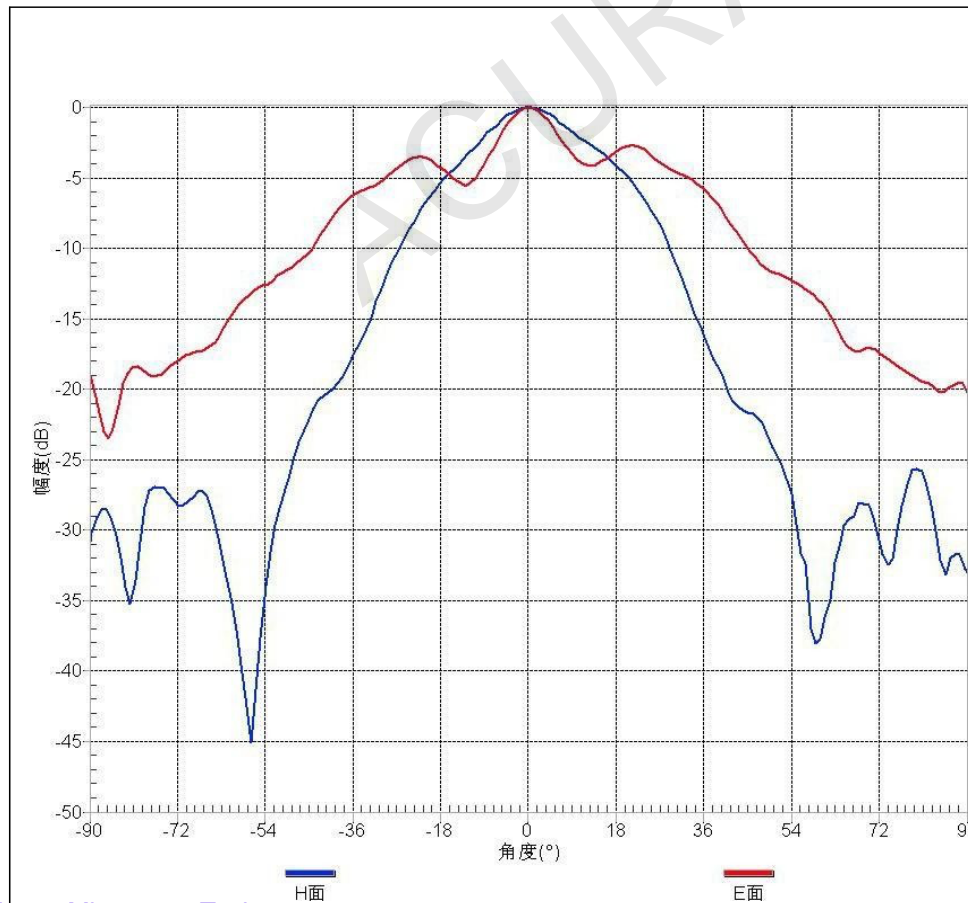

端口: 1
 频率: 15GHz
 增益: 11.60dB
 H 面波束宽度:
 -3dB: 25.82
 E 面波束宽度:
 -3dB: 29.74

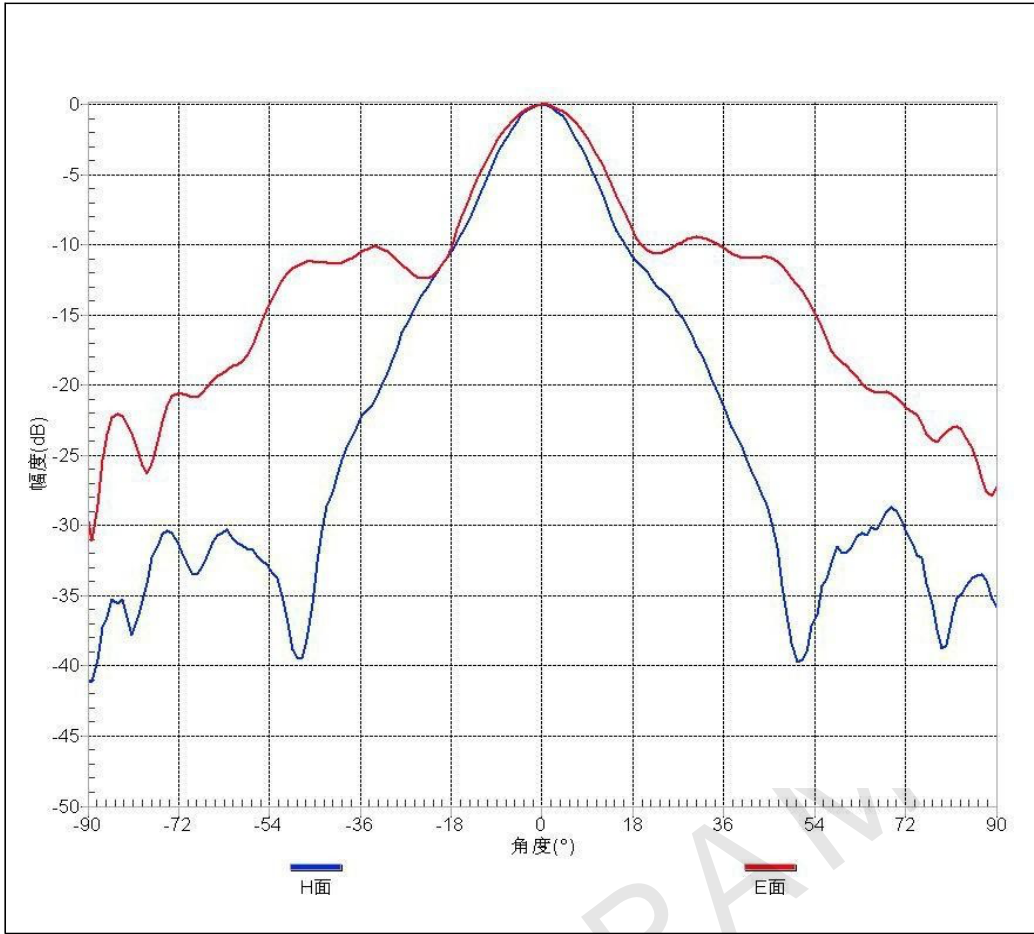

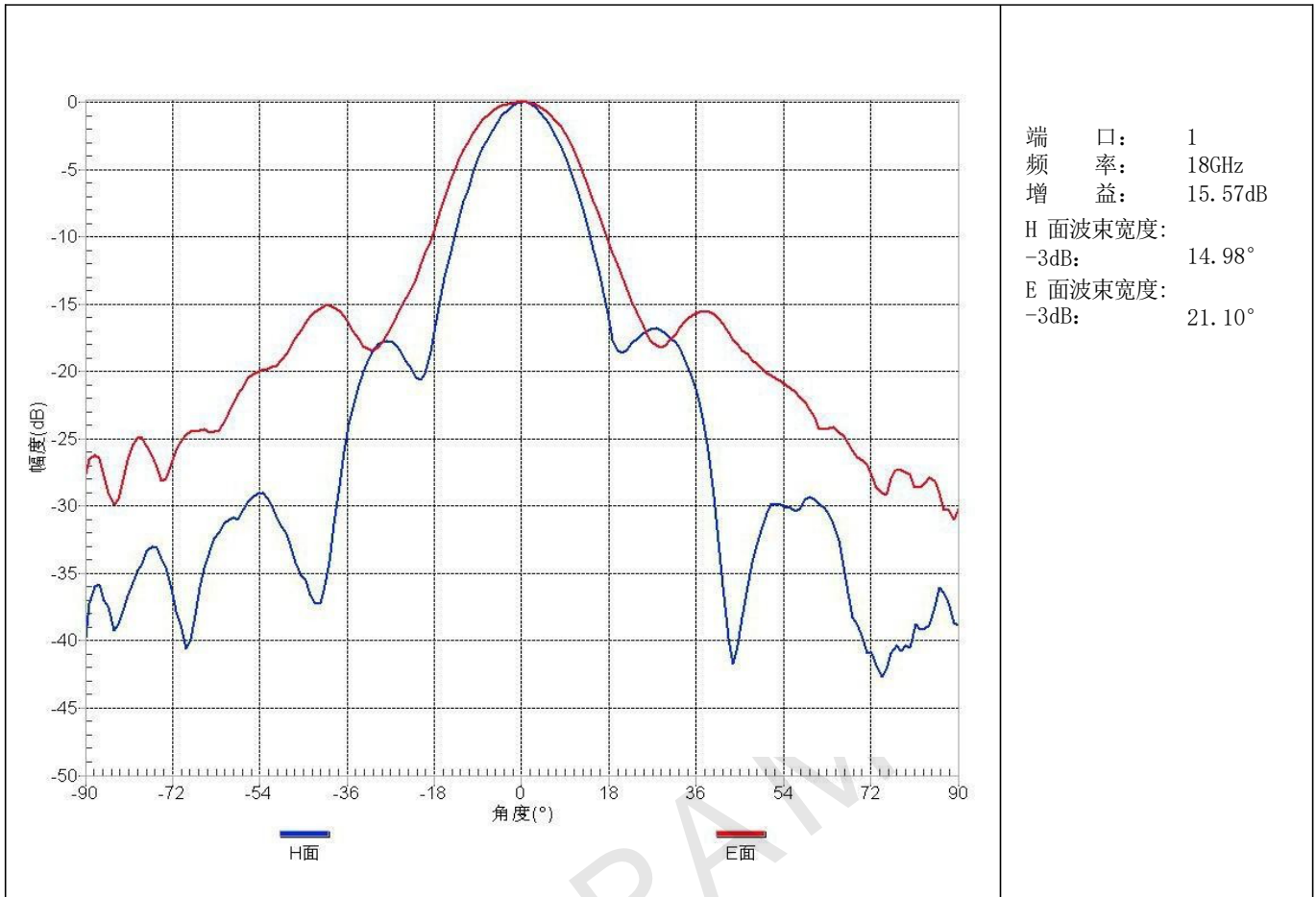

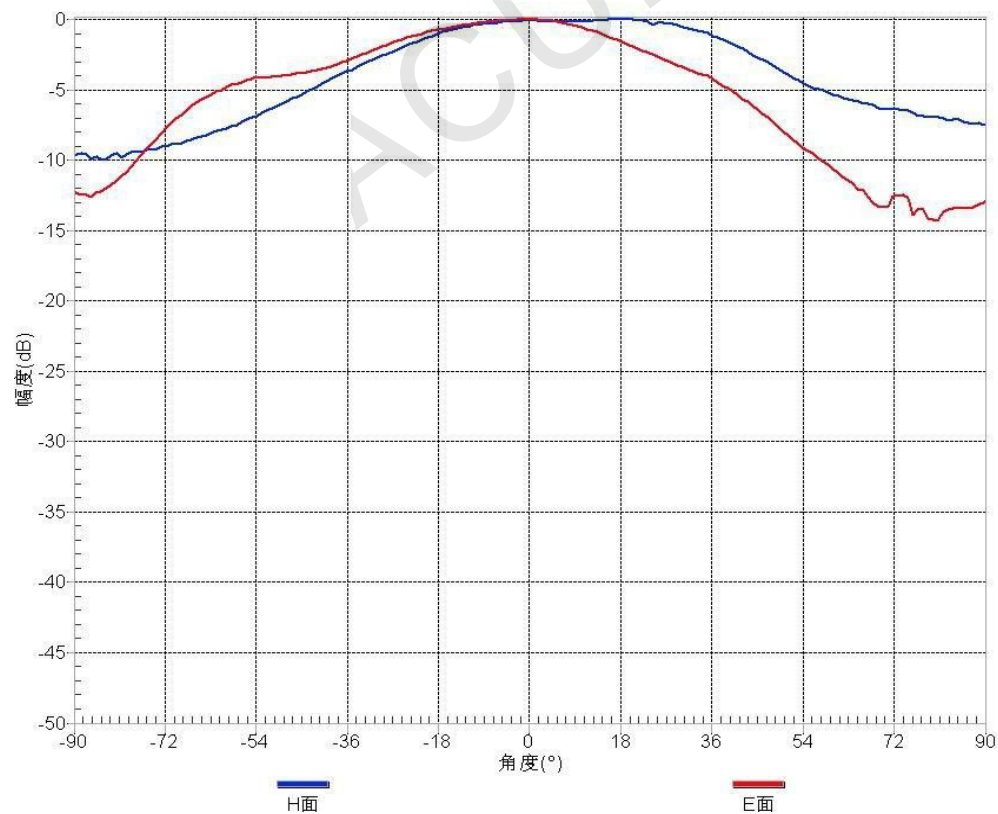
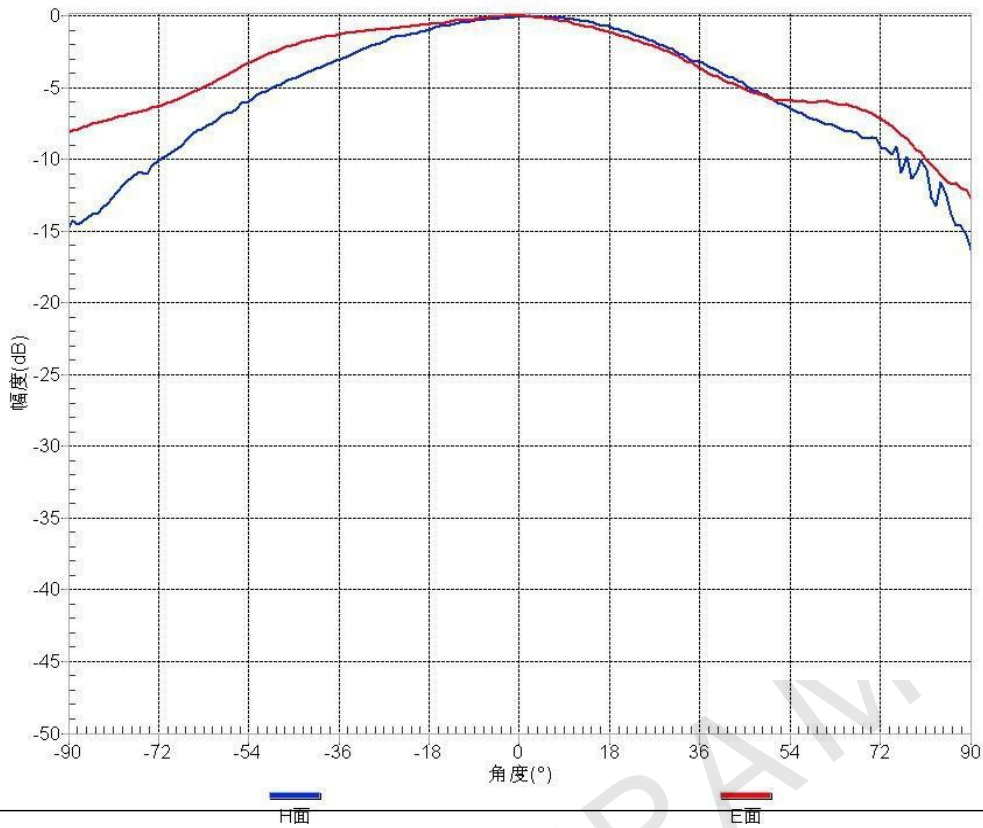

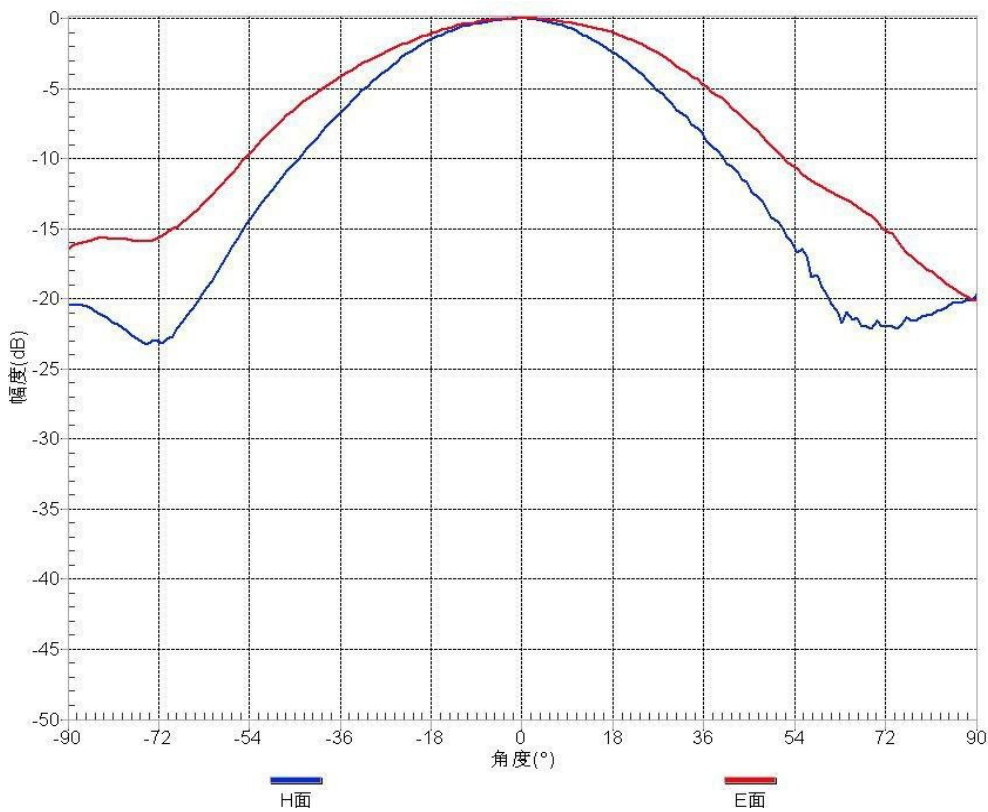

端口: 2
 频率: 4GHz
 增益: 9.45dB
 H面波束宽度:
 -3dB: 44.79°
 E面波束宽度:
 -3dB: 59.67°

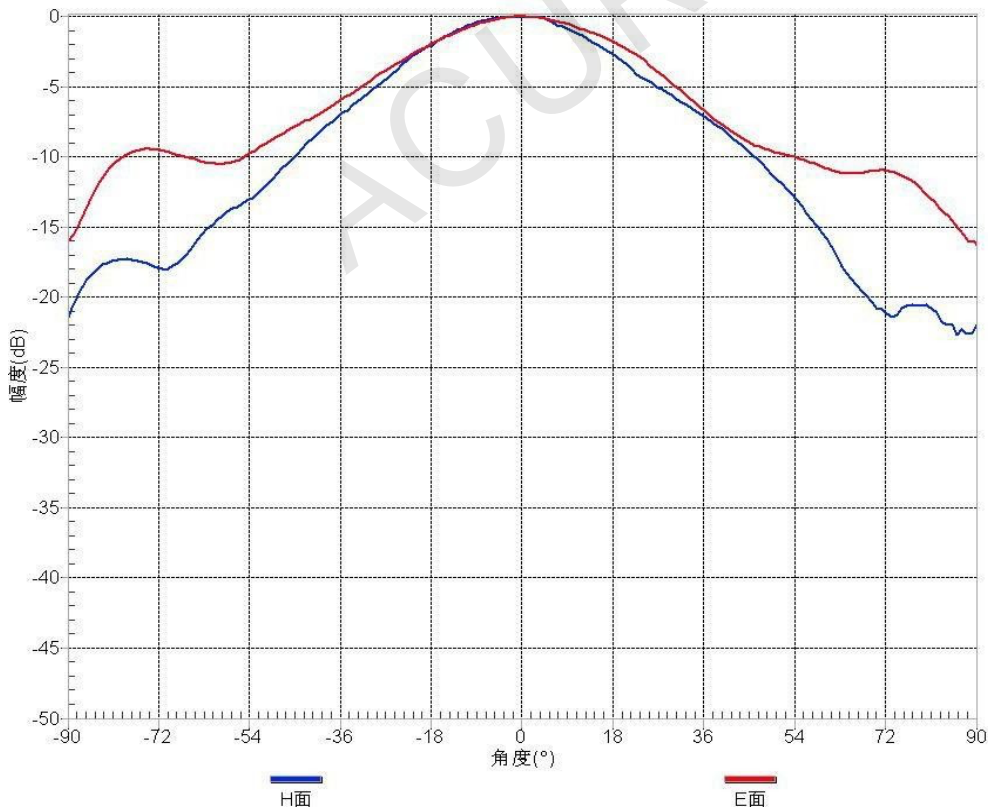

端口: 2
 频率: 5GHz
 增益: 10.02dB
 H面波束宽度:
 -3dB: 41.53°
 E面波束宽度:
 -3dB: 46.77°

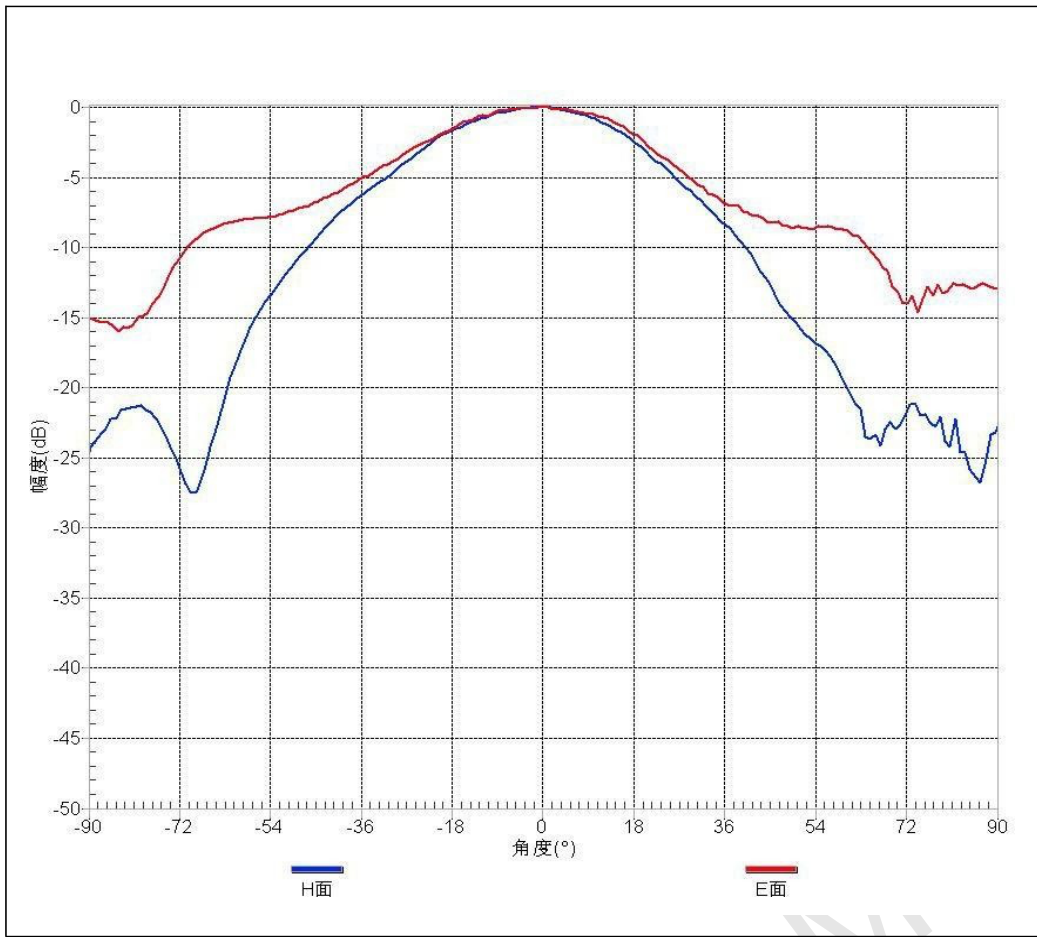

端口: 2
 频率: 6GHz
 增益: 11.87dB
 H面波束宽度:
 -3dB: 43.66°
 E面波束宽度:
 -3dB: 48.01°

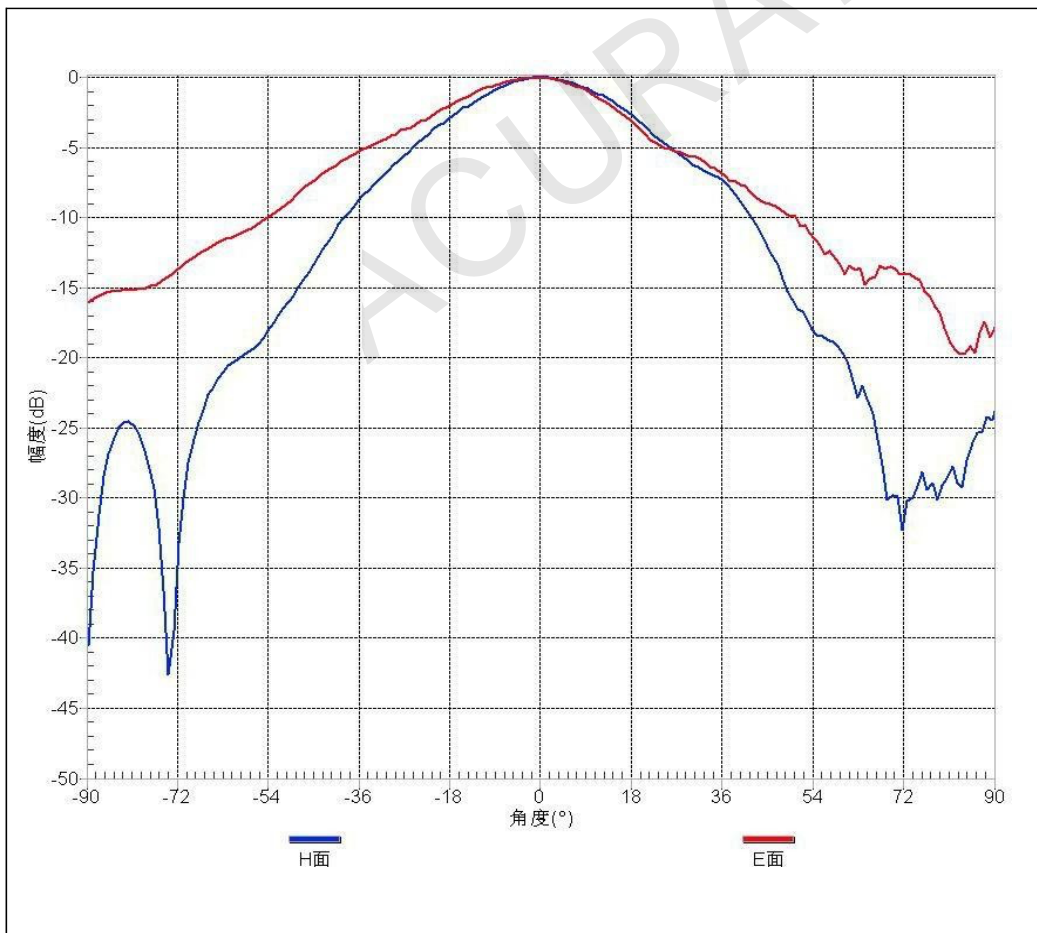

端口: 2
 频率: 7GHz
 增益: 12.69dB
 H面波束宽度:
 -3dB: 37.52°
 E面波束宽度:
 -3dB: 40.26°

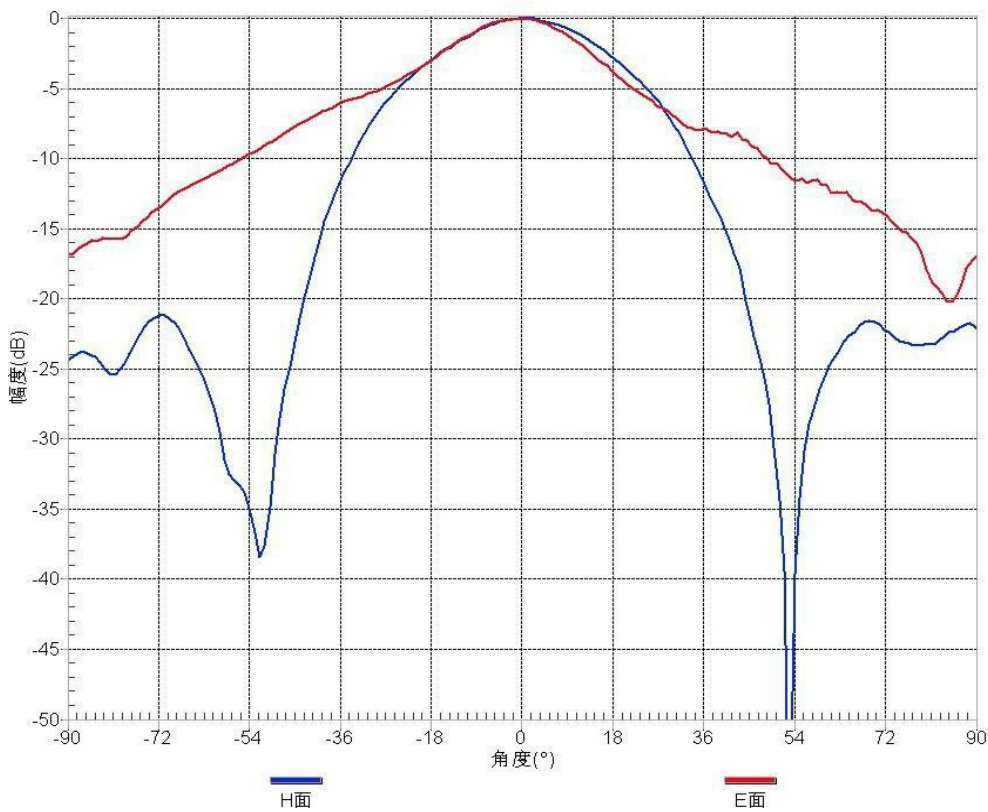

端口: 2
 频率: 8GHz
 增益: 13.56dB
 H面波束宽度:
 -3dB: 36.93°
 E面波束宽度:
 -3dB: 33.28°

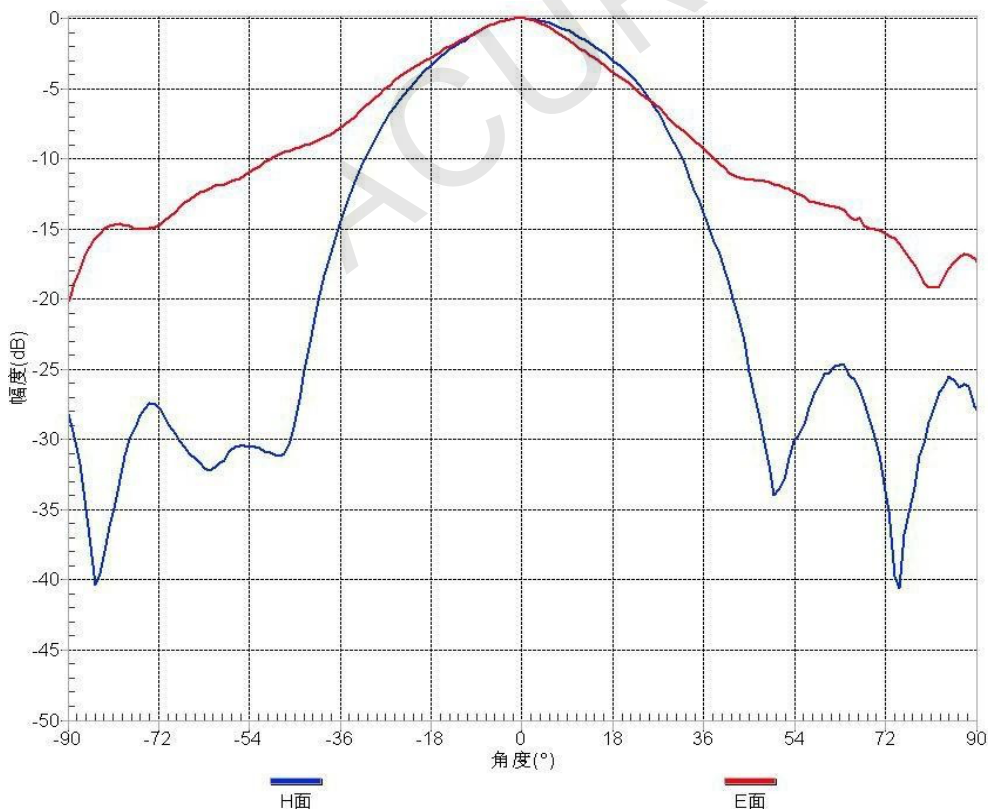

端口: 2
 频率: 9GHz
 增益: 12.48dB
 H面波束宽度:
 -3dB: 34.92°
 E面波束宽度:
 -3dB: 34.18°

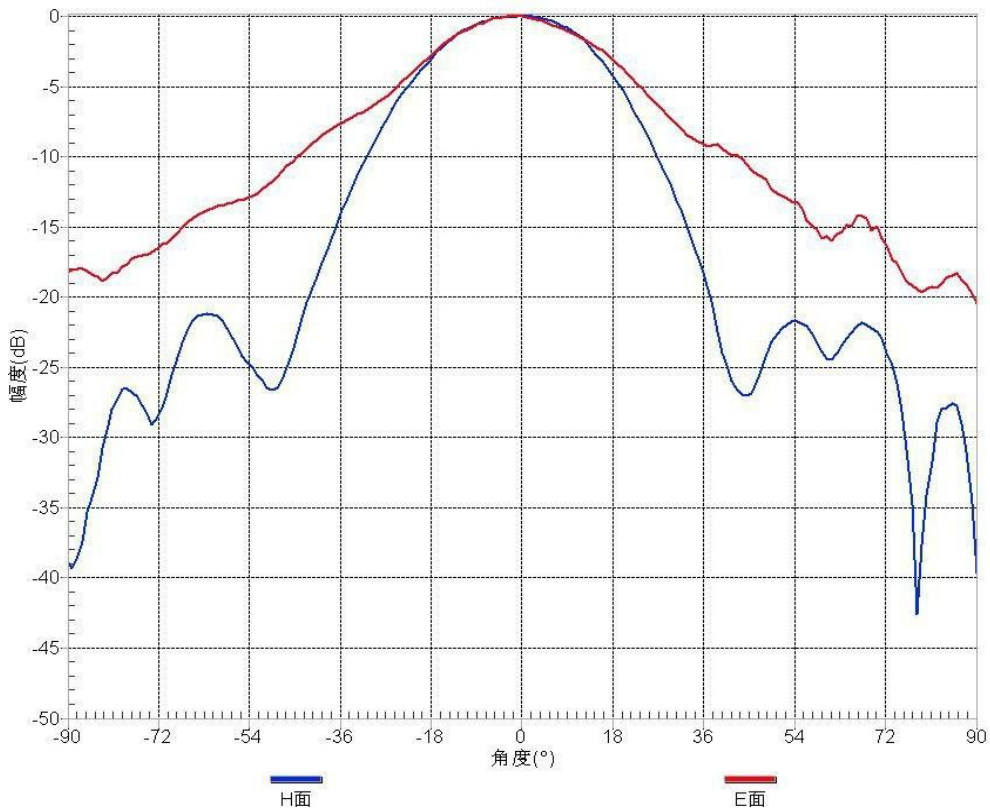

端口: 2
 频率: 10GHz
 增益: 12.37dB
 H面波束宽度:
 -3dB: 33.37°
 E面波束宽度:
 -3dB: 36.42°

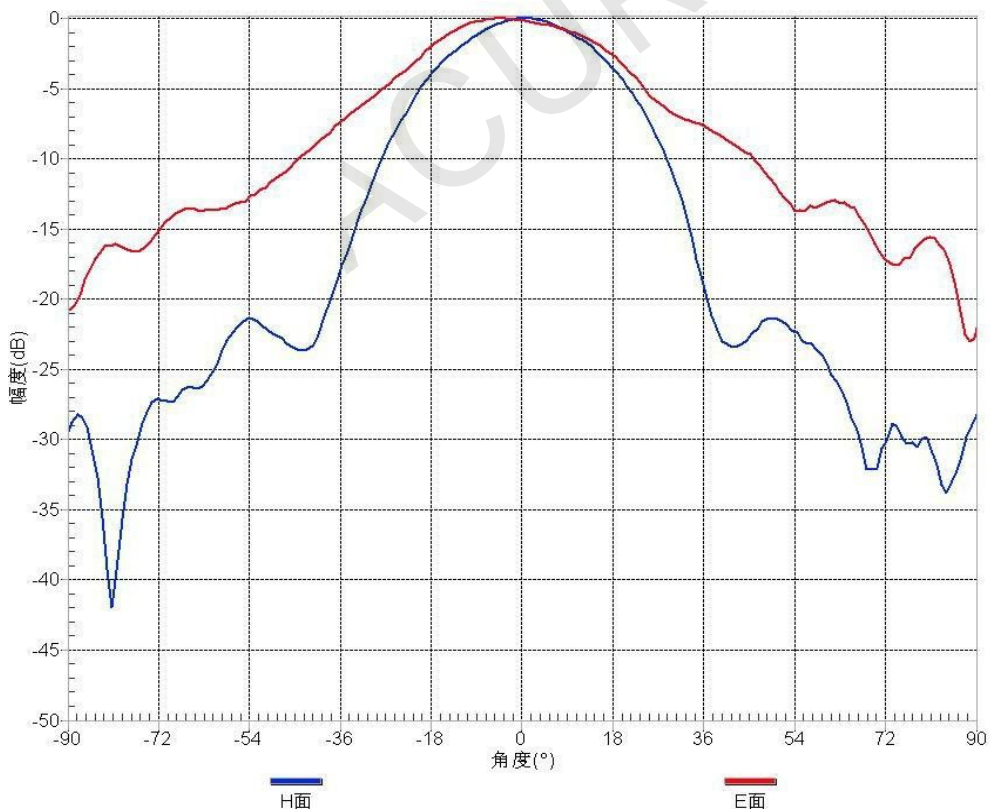

端口: 2
 频率: 11GHz
 增益: 12.29dB
 H面波束宽度:
 -3dB: 31.96°
 E面波束宽度:
 -3dB: 40.03°

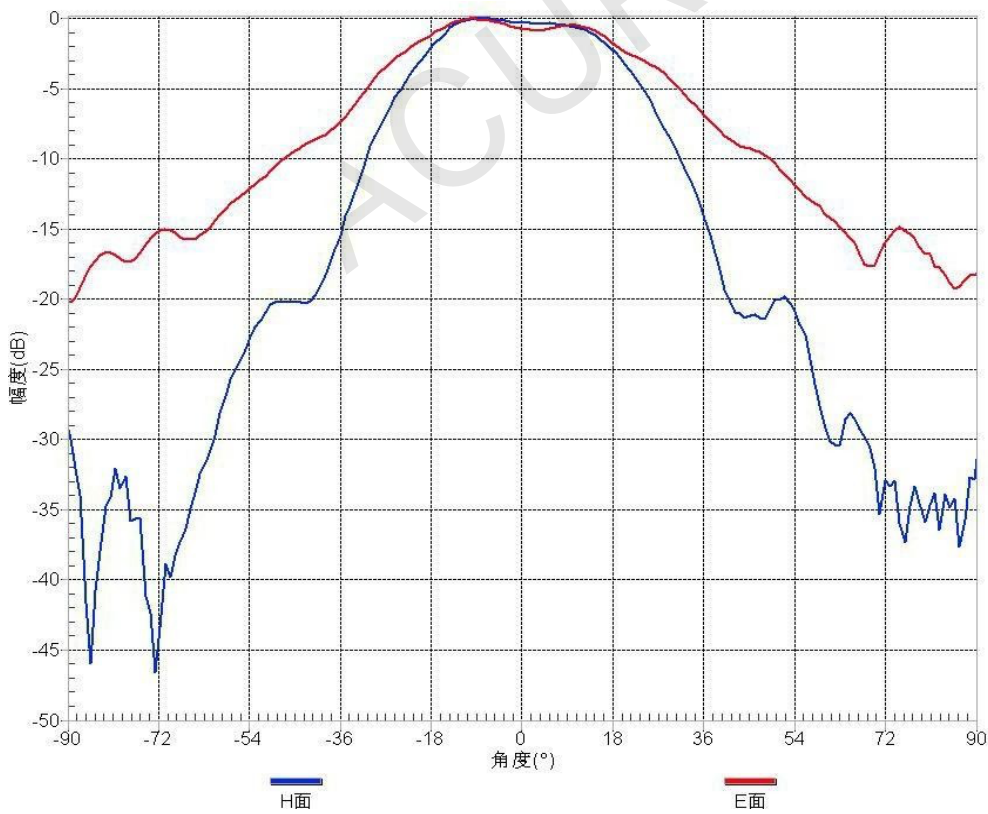
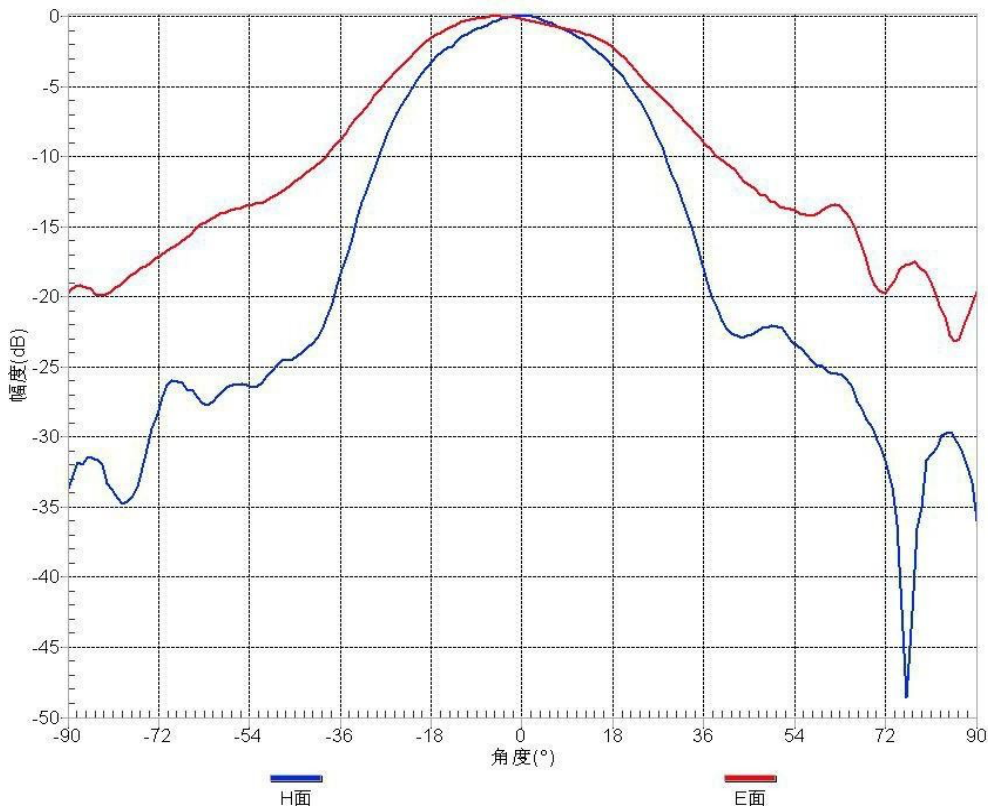

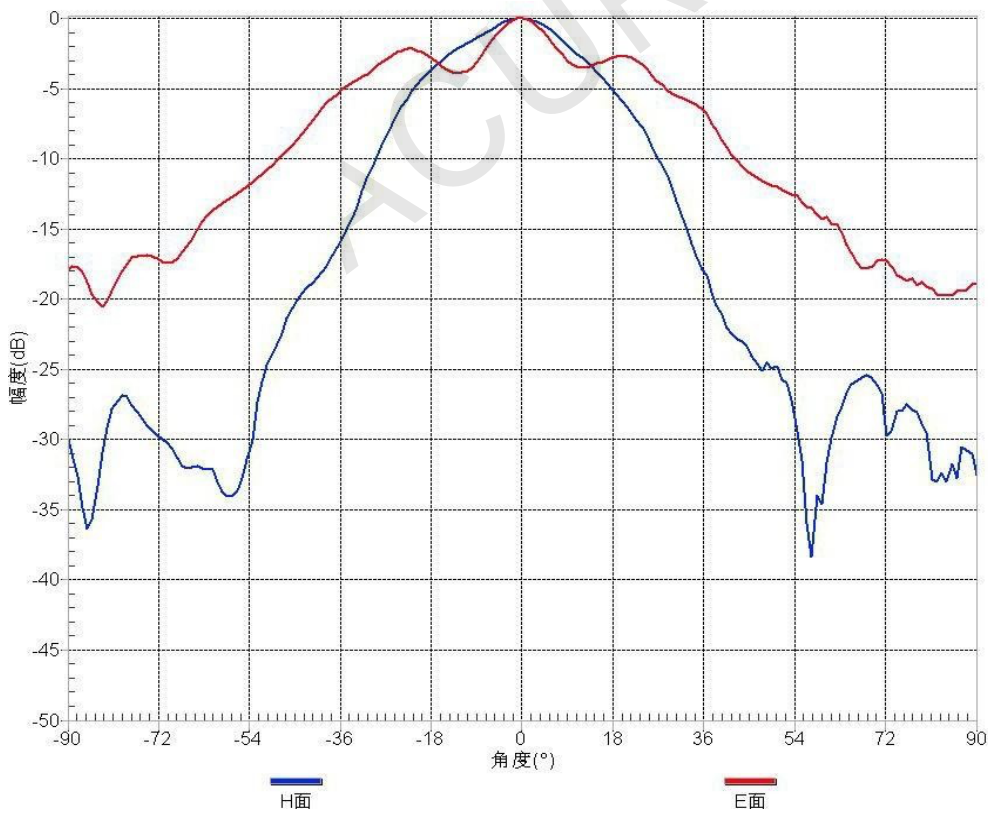
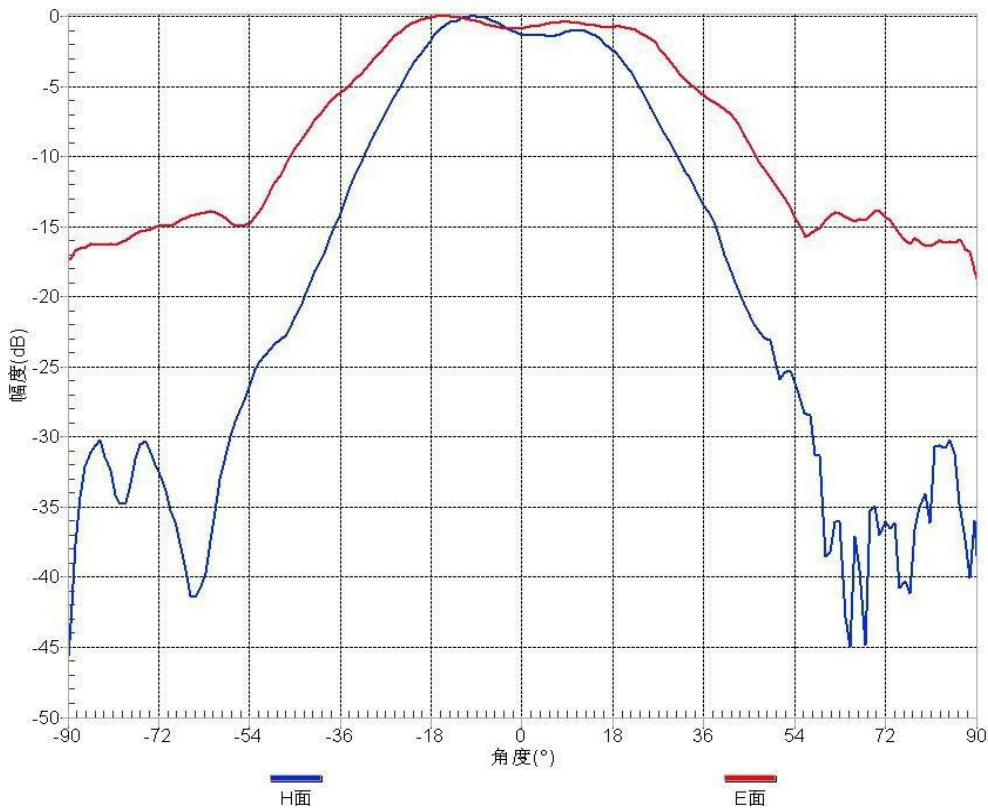

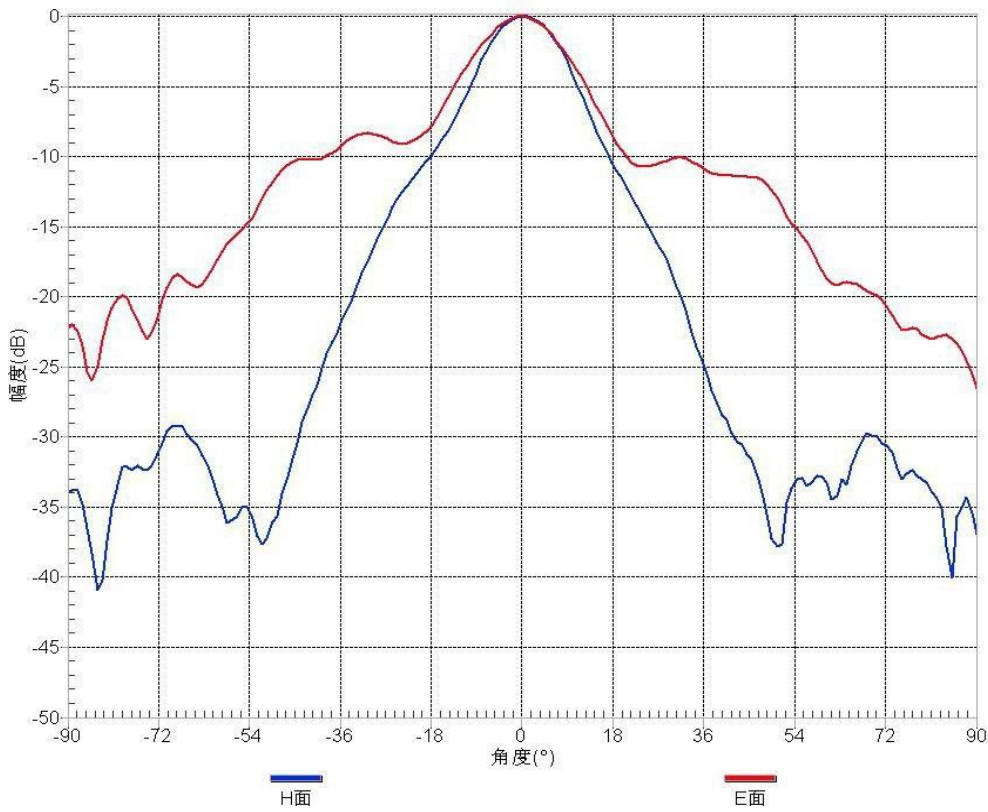

端口: 2
 频率: 16GHz
 增益: 14.97dB
 H 面波束宽度:
 -3dB: 16.61°
 E 面波束宽度:
 -3dB: 19.34°

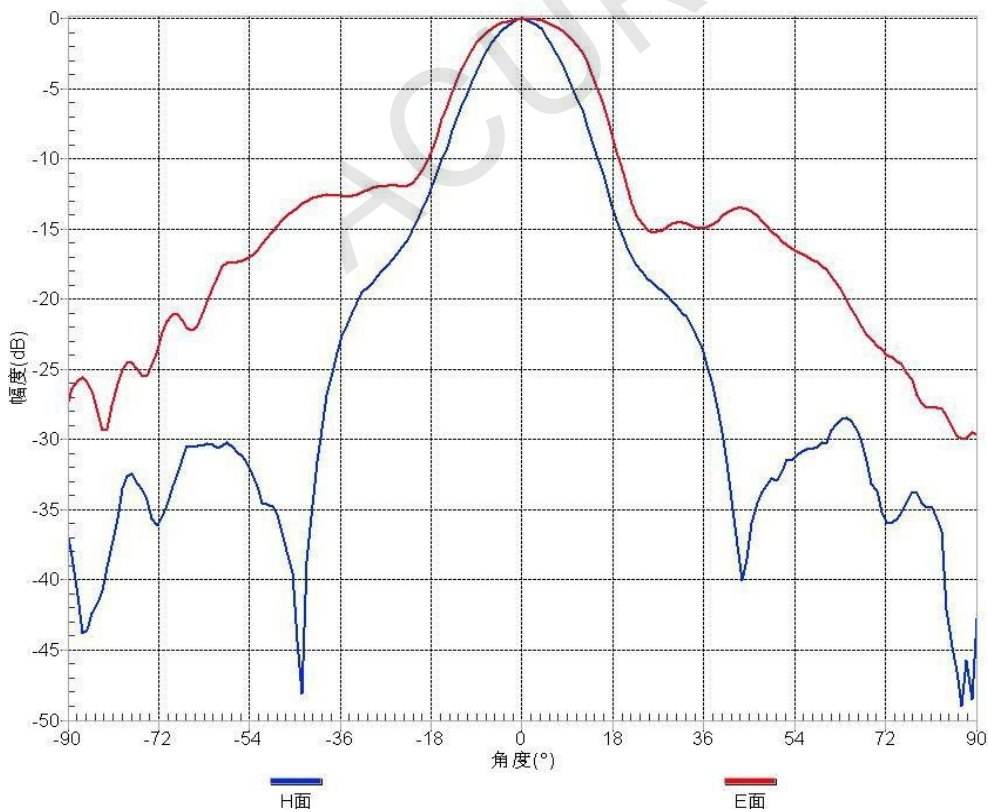

端口: 2
 频率: 17GHz
 增益: 16.07dB
 H 面波束宽度:
 -3dB: 15.37°
 E 面波束宽度:
 -3dB: 23.95°

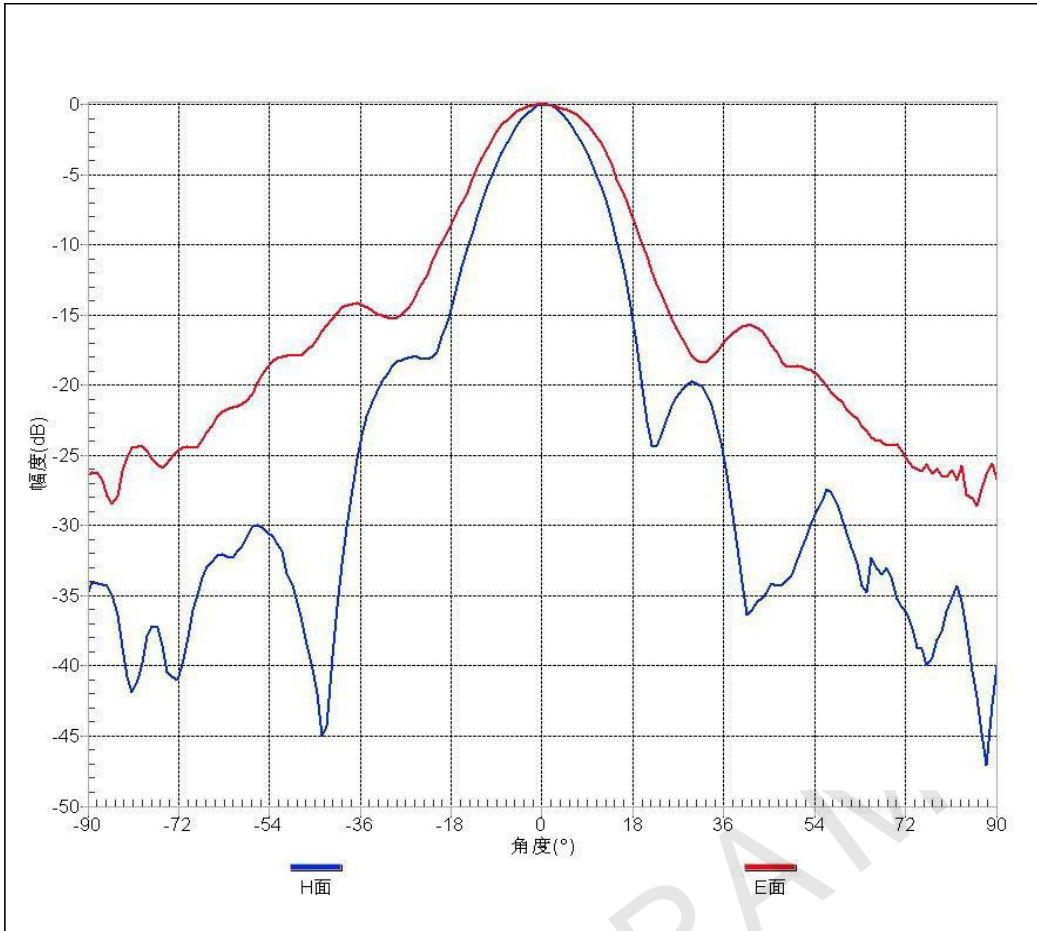

端 口: 2
 频 率: 18GHz
 增 益: 16.21dB
 H 面波束宽度:
 -3dB: 15.56
 E 面波束宽度:
 -3dB: 22.68

ACURAM