

AMT-ODP20180-SFSP0

Technique Specification

Frequency Range(GHz)	2-18
Gain(dBi)	10 Typ.
Polarization	Dual Polarization
VSWR	2.5 Max.
Connector	SMA-Female
Material	Al
Finish	Chemical Conversion Coating and Nickel Plated
Application	Outdoor, Waterproof and Dustproof, Fixed, meet IP65

Outline(mm)

Antenna without radome for reference.

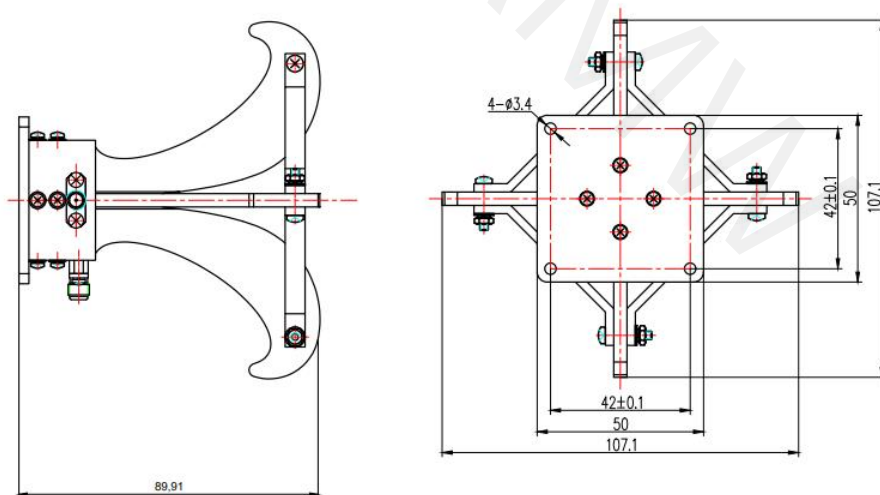

Gain

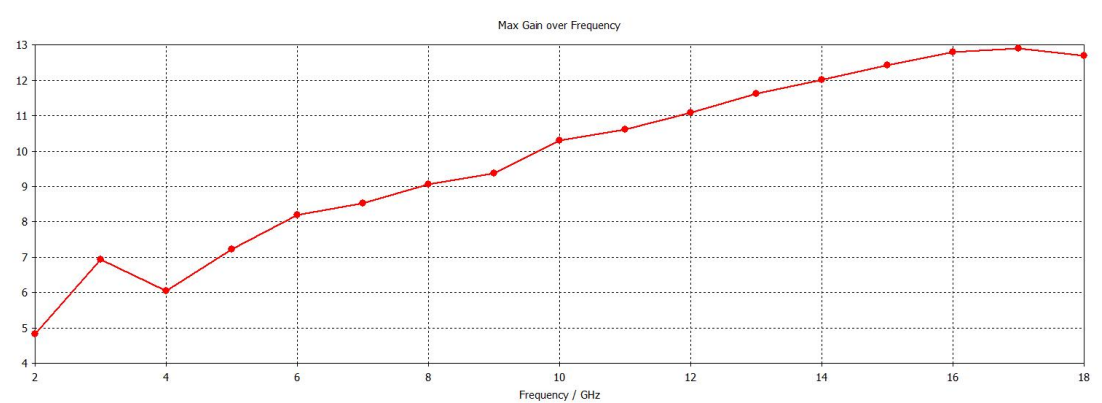

Return Loss

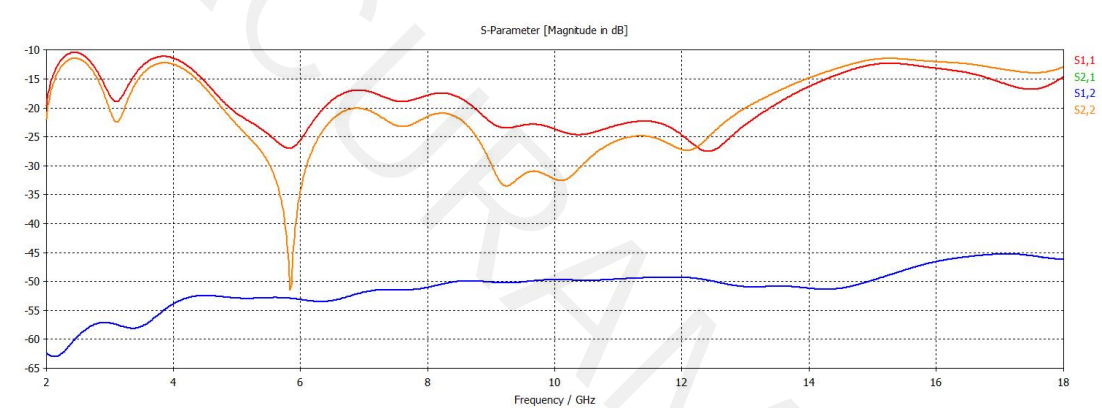

Directivity

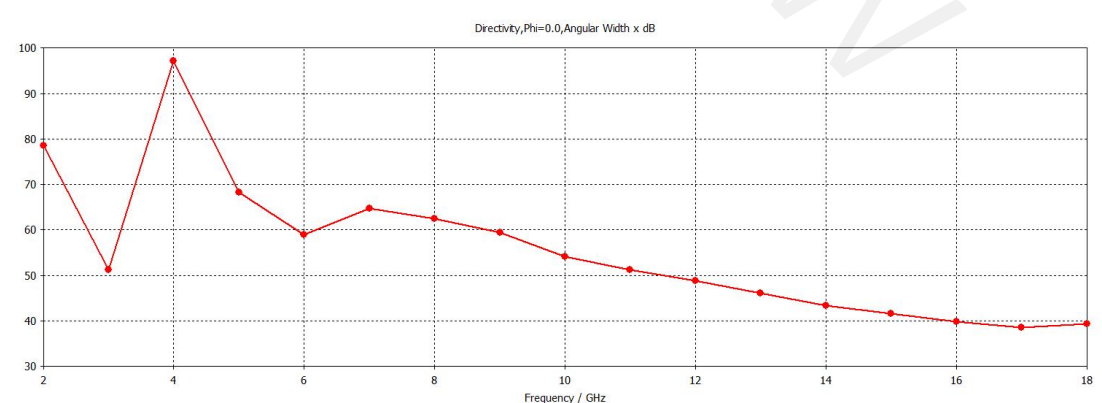

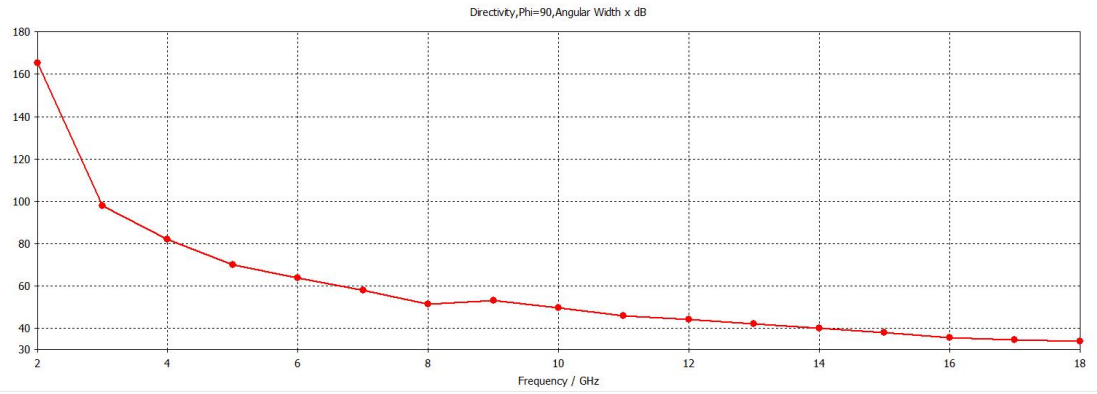

Pattern

